



P-BUA-MAVERICK

## Wiring Harness for Backup Alarm 2022 Ford Maverick

INSTALLATION MANUAL



**ECHOMASTER**  
**PRO**

Thank you for purchasing the  
**P-BUA-MAVERICK**

**Table of Contents**

- Page 3** - Tools Required For Installation
- Page 4** - Components and Wire Locations

**WHAT'S INCLUDED:**

- Vehicle Specific Wire Harness (P-BUA-MAVERICK)

**COMPATIBLE ACCESSORIES:**

- 97dB Backup Alarm (BUA-97C)
- 97dB White Noise Backup Alarm (BUA-97WNC)

**TOOLS REQUIRED:**



- 1. 10mm Nut-setter
- 2. 8mm Nut-setter
- 3. Impact Drill
- 4. Diagonal Cutters
- 5. Fish Tape

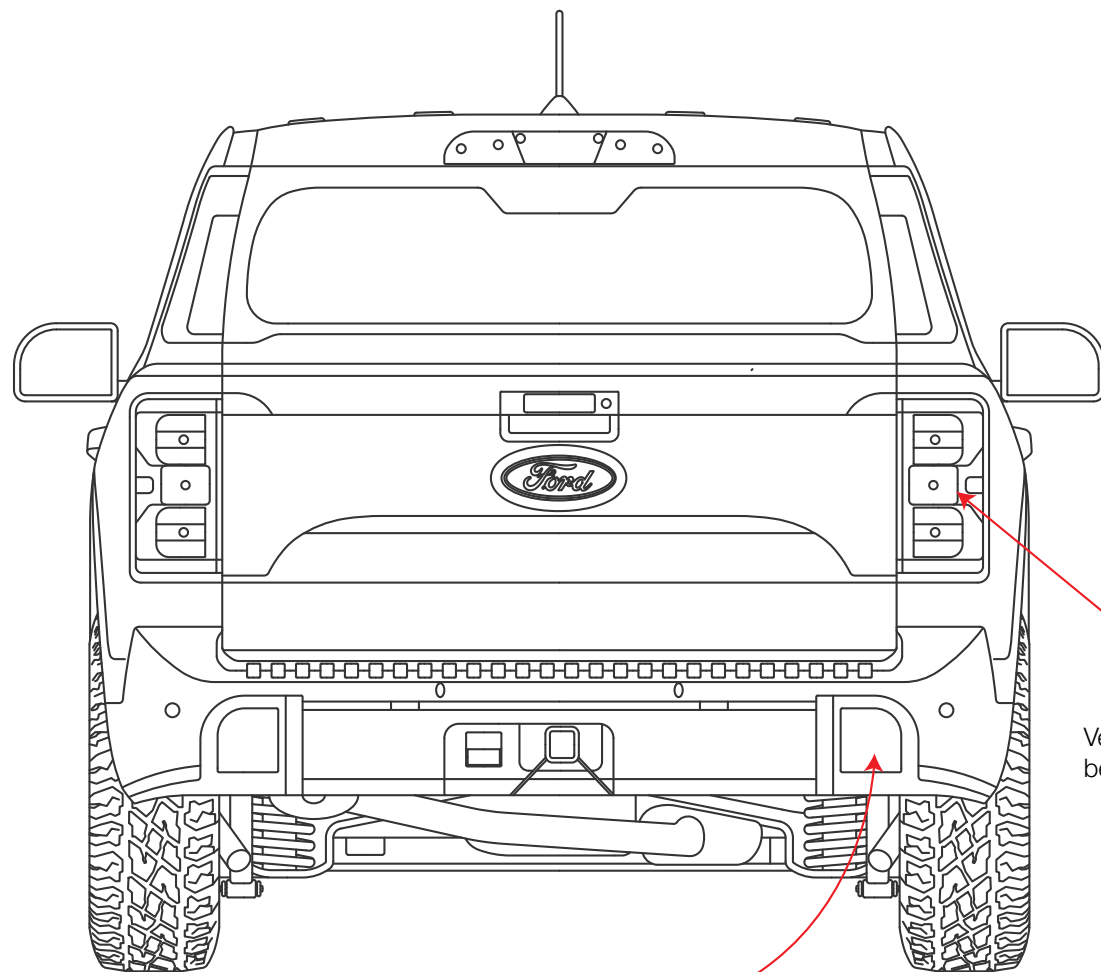

Backup Alarm Location  
(Mounted on passenger side of spare tire/on frame rail)

Vehicle harness connection  
behind passenger side tail lamp

### STEP 1:

Use an impact drill and 8mm nut-setter to remove the passenger side tail lamp.



### STEP 2:

Unplug the OEM connector and install the P-BUA-MAVERICK harness between the OEM connectors.



### STEP 3:

Route the harness down the tail lamp cavity and re-install the passenger side tail lamp. The mating connector for the backup alarm will come through the underside of the cavity just behind the spare tire.  
Note: Using a wire snake/fish tape helps with wire routing



**STEP 4:**

Use an impact drill and 10mm nut-setter to install a compatible backup alarm on the underside of the vehicle

Note: (2) 10mm TEK screws are provided with the compatible backup alarm



**STEP 5:**

Plug the backup alarm connector into the mating connector on the P-BUA-MAVERICK harness. Secure any excess wiring with cable ties. Use diagonal cutters to remove excess cable tie material.

**STEP 6:**

Test the backup alarm



Phone: 866.931.8021 (Option 3)  
Email: support@aampglobal.com

EchoMaster is a Power Brand of AAMP Global

EchoMaster.com

.....